

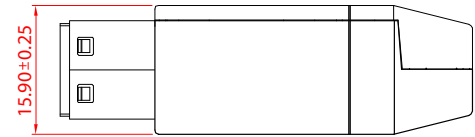

REVISIONS		
REV	DESCRIPTION	DATE
A	RELEASE FOR QUOTE	10/2006

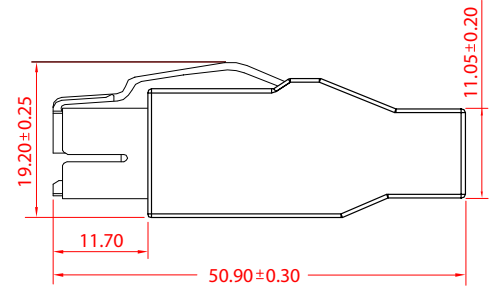
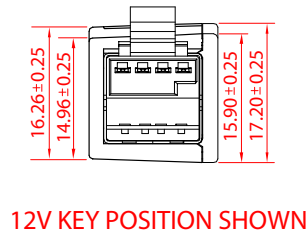
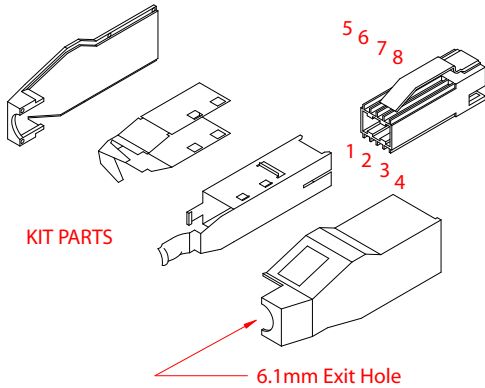

Notes: All materials conform to EN Directive 2002/95/EC for RoHS Compliance.

Electrical characteristics:

Ratings: 3.0A

Contact resistance: 30mΩ Max. (Initial), 400mΩ Max. (After life test)

Insulation resistance: 1000 MΩ min.

Dielectric strength: 750V AC / 1 minute.

Mechanical:

Insertion force: 6.6 kgf max.

Withdrawal force: 1.0 kgf min.

UNLESS OTHERWISE SPEC'D DIM. ARE IN MILLIMETER. TOL. ARE: FRACTION DECIMAL ANGULAR ± ± ± 1/2"		RoHS DIRECTIVE		THIRD ANGLE PROJECTION		CONQUEST TECHNOLOGY LIMITED				
MATERIAL		APPROVALS		DATE		12V Powered USB Plug, Pebble Grey - RoHS				
FINISH		DRAWN Spock		10/05/06		SIZE A	DWG. NO. 371223		REV A	
DO NOT SCALE DRAWING						SCALE: N/A		SHEET 1 OF 1		